

8. Aftercare

The cabinet surfaces will usually only require dusting. Avoid products that are abrasive, or contains acid, alkali or antibacterial agents. Marks on the paint surface may be removed with diluted soap solution. Remove any remaining marks by spraying with a proprietary glass cleaner and lightly wiping dry with a micro-fiber cloth. Do not use cleaning agents on the drivers and avoid touching them.

Keep cabinets away from heat sources (radiators and warm air vents) and direct sunlight sources. Avoid placing loudspeakers in very moist or wet conditions. Expect some gradual color changes as the cabinets age. This is normal for any wood furniture.

9. Specifications:

- Range 40Hz – 25KHz anechoic
- 87dB 1w@ 1m
- Dimensions: 230 x 236 x 410mm
- 1 x Sota 5 wide-range cone tweeter
- 1 x Sota 11 wide-range cone bass-mid
- Weight (each) 8.5 KG



www.markaudio-sota.com

Unit 609-610, 6/F., Bio-Informatics Centre, 2 Science Park West Avenue,
HK Science Park, Shatin, NT., Hong Kong

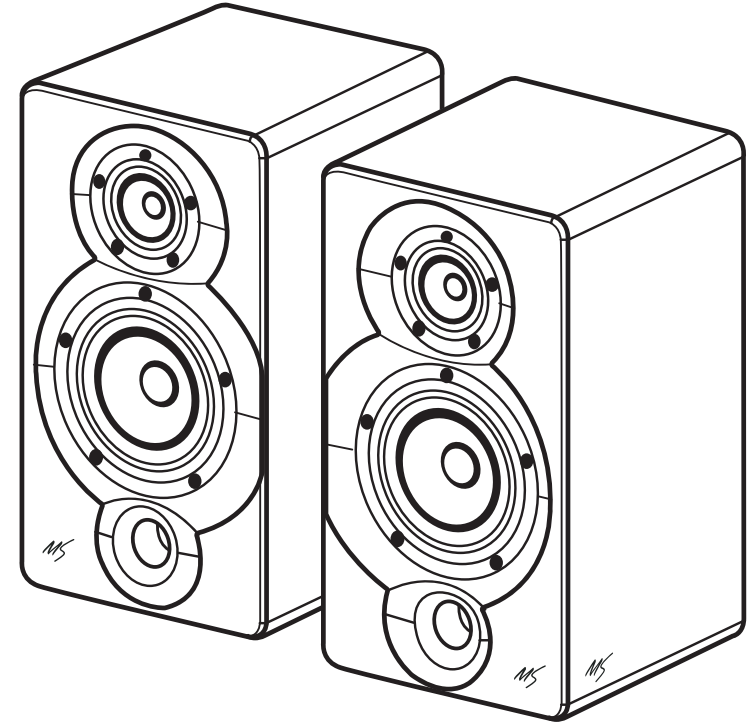

CESTIB

USER MANUAL

Welcome and thank you for choosing MarkAudio Sota.

Markaudio-Sota's engineering approach using full range audio driver technology with minimal control networks and laminate cabinet construction are the keys that can unlock the enjoyment of audio in the home. This is a high performance product that rewards careful amplifier, source and cables selection along with thoughtful room positioning.

 Please take the time to read this manual before you begin.

1. Unpacking

Carton contents: Please check in the carton for :

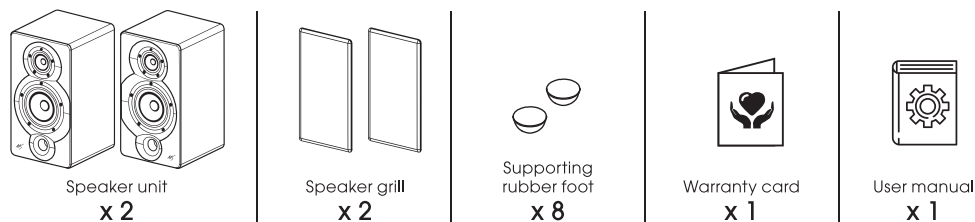

2. Environmental Information:

This product complies with international directives, including but not limited to:

- The Restriction of Hazardous Substances (RoHS) in electrical and electronic equipment,
- The Registration, Evaluation, Authorisation and restriction of Chemicals (REACH)
- The disposal of Waste Electrical and Electronic Equipment (WEEE).

Please consult your local waste disposal authority for guidance on how properly to recycle or dispose of this product.

All bags should be kept away from babies and small children.

3. Speaker Installation:

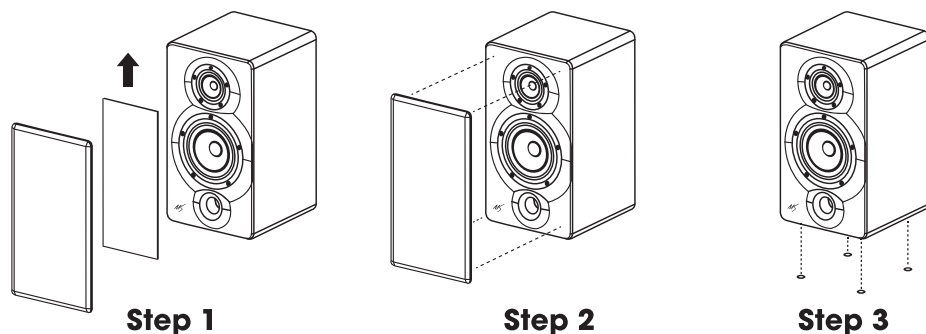

Install the speaker grill to cabinet front surface by take away the protection cardboard underneath the speaker grill. Magnet on speaker grill and cabinet will align the position.

The speaker is primarily designed to be mounted on 4 supporting rubber foot (supplied).

4. Speaker Positioning

Room acoustic performance varies. Adjusting the speaker positions may further improve the sound quality. Typical placement of loudspeakers is either side of a TV. Start by placing the loudspeakers approximately 2.5 metres to 3 metres apart with a minimum clearance from a back wall of 100mm. Experiment by angling the loudspeakers toward or away from your central listening position to suit your tastes.

5. Connections

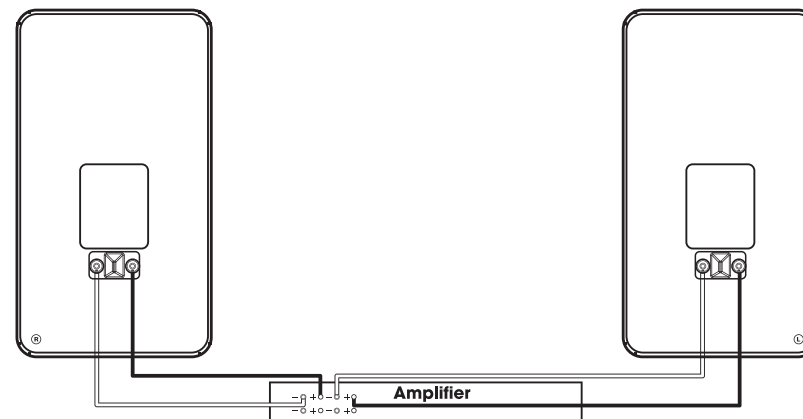

All connections should be made with the audio equipment **switched off**.

Ensure terminals to each loudspeaker are correctly connected. Follow our wiring cable diagram. Connect the positive feed from the amplifier to the red loudspeaker terminal. The negative amplifier feed connects to the black terminal on the loudspeaker.

6. Amplifier Recommendations

Nearly all Loudspeakers are passive components. They can only perform at their best if amplification, source and cable components are of high quality.

Careful and thoughtful choice of a suitable amplifier should optimise performance. Suitable amplifiers will range from: Class A/B 50 Watts to 100 Watts per channel at 8 Ohms. Class A from 12 Watts to 25 Watts per channel at 8 Ohms and Class D from 30 Watts to 60 Watts per channel at 8 Ohms. Amplifier design and performance varies so these recommendations can only be a guide.

Source components such as CD players, DAC's and similar vary in performance quality. Take time to research better quality components and recordings. Cables can also effect performance. Be prepared to experiment with cables to suit your listening tastes.

7. Running In

Markaudio-Sota speaker drive components are engineered to tighter tolerances than most other units. Careful thoughtful running-in and general operation will be rewarded by many years of faithful service. Use low volumes for the first 100 hours to allow the driver suspensions to adjust to their normal tolerance.

Over-driving loudspeakers (high volumes) risks damaging the drive units. It is also a major cause of human loss of hearing.